

Manufacturer: Quick Bauprodukte GmbH
Test requirements: Test instruction fibre concrete "Norwegian Standard"
Material / Mixture-No.: Quick fiber concrete M1
Concrete quality: C45/55
Exposure class concrete: acc. to Eurocode 2 (EC2) X0 / XC4 / XD 3 / XF4 / XA2

Article / Article-No.: Mounting-Bipo 50 without wire / 22036
Concrete cover: 50 mm
Production date: 02.03.2022
Test period: 19.04.-22.04.2022

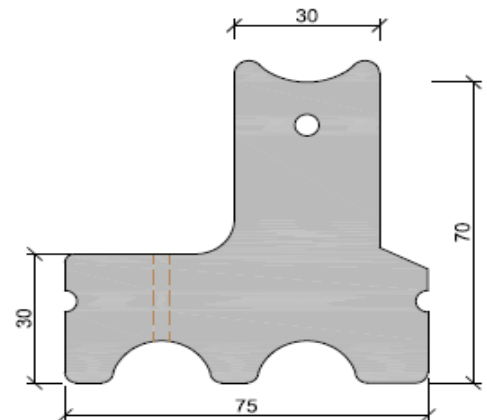

Results dimension test

Part No.	H	Vippediagonal
1	51,0	60,0
2	51,0	61,0
3	51,0	61,0
mean	51,0	60,7

Results water absorption test

Part No.	Storage weight in g after 48 hours heat treatment curing at +105°C	Weight in g after 30 min. immersion	Water content in % after 30 min. (to be < 5 %)	Weight in g after 24 hours immersion	Water content in % after 24 hours (to be < 8,5 %)
1	200	206	3,0%	214	7,0%
2	199	204	2,5%	212	6,5%
3	196	202	3,1%	210	7,1%
mean			2,9%		6,9%

Results breaking load test

Part No.	breaking load F / kN (to be >6 kN)
1	7,5
2	7,3
3	8,0
mean	7,6

This certificate complies to the requirements of DIN / EN 10204:2005-01-3.1

The buyer is not released from any entry control.
It is also irrelevant in case of incorrect use or handling.